

D2000M SERIES

Intrinsically Safe Modular

Multiplexer System

for Installation in Hazardous

Areas Zone 0, 1, 2

Gas Group IIC, IIB, IIA T4

Class I, II, III, Div. 1, Groups A,

B, C, D, E, F, G, Indoor and

Outdoor Hazardous Locations



Transmit up to 7936 Analog, or 3968 Digital, Signals from TC, RTD, mV, 4-20 mA, or contact, Proximity sensors, at distances as far as 5000 meter.

D2000M Series Intrinsically Safe Modular Multiplexer System

System Features

- High Density, up to 256 Analog Inputs (TC, RTD, mV, mA, Ohm) and up to 128 Digital inputs (Contacts, Proximity sensors) on the same system.

Expandable up to 7936 Analog and 3968 Digital.

- Robust Galvanic Isolation (± 200 V channel to channel) provides high immunity against interferences and ground loops.
- Operates in Hazardous Areas (zone 0, 1, 2, 20, 21, 22, or Class I, II, III Div. 1 groups A, B, C, D, E, F, and G indoor and outdoor) with no need of barriers.
- Send data as far as 5 Km distance at high speed 38400 baud.
- High Accuracy 18 bits D/D converter.
- Direct connection of sensors to input plug-in type Terminal Blocks. No auxiliary Terminal Blocks required.
- Communication line, used also as Supply line, can be redundant.
- IEC Ex, ATEX, FM, FM-C, GOST Certifications.
- System configuration software performed [SW free of charge].

- Interfaces with PLC/DCS via redundant Modbus RTU protocol.
- Connects directly to PC RS 232 port for system configuration and diagnostic.

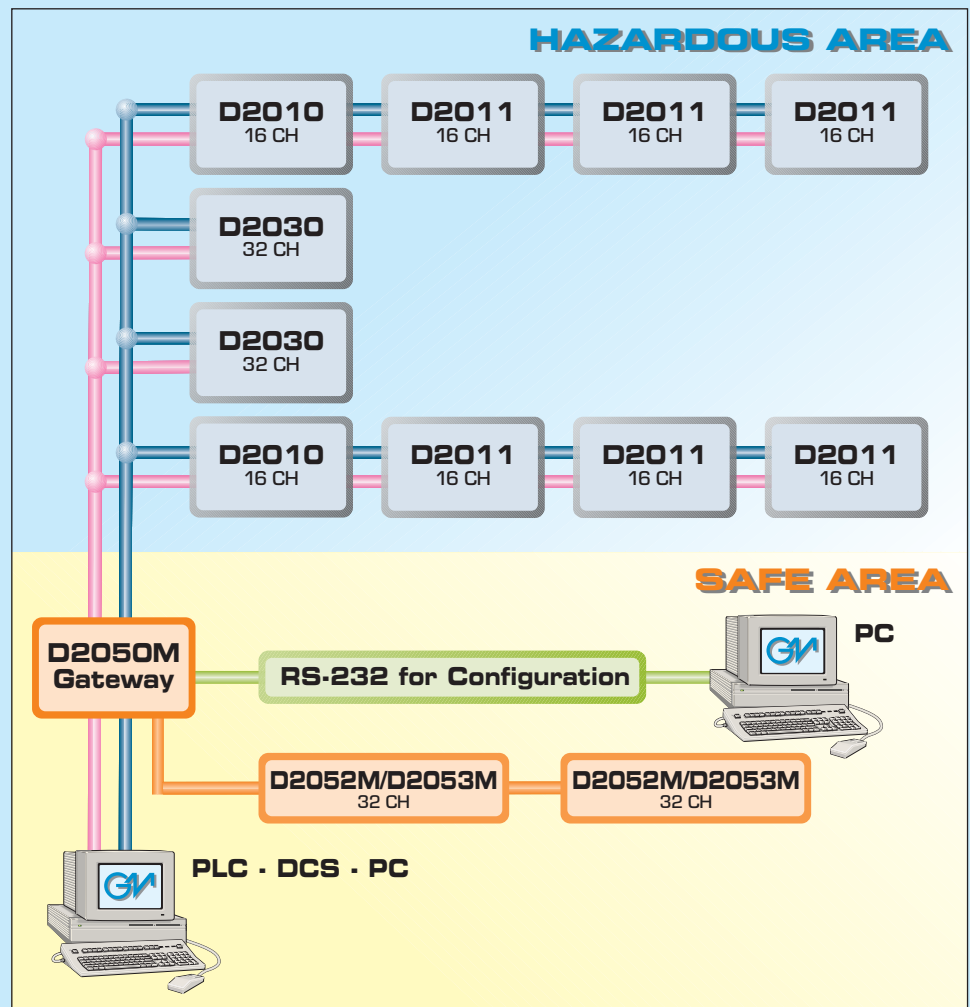

- Repeats input contact via Relays or O.C. Transistor Outputs.
- Lower Cables and installation costs.
- Lower PLC-DCS I/O card costs.
- Lower wiring costs, 1 terminal Block per input connection, no auxiliary T.B. needed.
- Simplified Installation.

Brief Information about Multiplexing Technique

Signal Data Acquisition

In industrial process is a common need to acquire a relevant number of temperatures, pressures, flows, levels and other process variables as well as the status of switches or proximity sensors and collect all these data in a single remote collection area (i.e. in a control room) where a PLC (Programmable Logic Controller) or a Process Computer collect all data and use them for monitoring purposes or make them available to the operators.

SCADA (Signal Conditioning And Data Acquisition) equipment are particularly suited for this purpose.

Modern micro electronics permits fast, accurate and stable Analog to Digital converters, high speed computing, sophisticated intelligence and powerful measuring capabilities.

All this performance can be packed into compact reliable units that can operate in harsh environments.

Multiplexers are a typical SCADA multi channel equipment that can be located in the field close to the process area where the input channels can be connected with short lines. All input channel signals are converted in a numeric form and transmits to a remote location via a single communication line.

How a Multiplexer works

The multiplexer cyclically scans each input channel for a few milliseconds (connects with electrical or semiconductor switches each input signal, one at a time, to the internal circuits) and converts with an A/D (Analog to Digital) converter each process signal into a digital value.

This digital value is computed by a microprocessor and transformed into a numerical data expressed in terms of engineering units corresponding to the effective process variable of the channel (°C, PSI or ATE, liters/sec etc). After completion of the scanning and conversion cycle of one channel the multiplexer connects the next channel in a sequential fashion so that in a few milliseconds all input

channel signals are converted into their corresponding numerical data, expressed in engineering units and stored on a buffer memory.

Multiplexers also perform tagging of each variable for channel identification and diagnostic functions to detect failures, out of range values, errors in the data etc.; all data are transmitted under command in a numerical form as a sequence of strings via a single serial communication interface and connection line up to the data collection area (i.e. in a control room).

Communication line can serve also as supply line eliminating the need of an extra power line. Additionally, the supply/communication line can be dual redundant to eliminate the effects of failures in one of the lines.

When multiplexing is the only viable solution

In the case of revamping or add-on of new parts in the plant, the space for adding cables may be limited or the few existing spare cables are the only ones that can be used.

Radio Frequency links, beside cost and licensing problems, present severe data security and reliability limitations that make, most of the times, this technique impractical. Multiplexer becomes the only practical solution.

The advantages of multiplexing

When a consistent quantity of variables must be made available to a far location, instead of wiring each process variable signal with long individual connection lines up to the control room, it is advantageous to connect all input signals to a conveniently field located Multiplexer with short local connections lines to the sensors and to send all data through a single communication line to the remote data collection area. Even when space for cable is available the saving just in cable cost alone justifies, most of the times, the multiplexer solution, in addition a tidy simple connection is obtained avoiding cluttering of wires in the control room area.

Multiplexing in Hazardous area

For applications in classified hazardous areas each signal must be protected from the risk of causing an ignition of flammable mixtures, this requires a safety barrier for each input channel and a protection for the multiplexer itself and its communication line substantially increasing the complexity and cost of such a solution.

The advantages of using an Intrinsically Safe Multiplexer

The use of an intrinsically safe multiplexer allows to install the equipment in hazardous area and to connect all of its inputs directly to the process variable signals without the requirement of any further protection; retaining the simplicity and cost effectiveness of a multiplexing solution. In addition to the cable cost and simplicity of installation discussed above, the elimination of safety barriers drastically simplifies and reduces the cost of this solution compared to other options.

D2000M Series General Description

The D2000M Series Intrinsically Safe Multiplexing System consists of one to four Analog-Temperature Multiplexer Units model D2010M, with up to 12 Expander Units model D2011M and up to four D2030M Digital Multiplexer Units, mounted in Zone 0, 1, 2 Hazardous Area, Gas Group IIC, IIB, IIA, T4 or Class I, II, III, Div. 1, Groups A, B, C, D, E, F, G Hazardous Location, connected via a single or redundant 2 wire data communication / Supply line to a Modbus Gateway Unit model D2050M, mounted in Safe Area and connected to a PLC, DCS or PC.

The Multiplexer Units D2010M, and the Expander Units D2011M can be installed in the field, close to input sensors, for data acquisition from Hazardous Areas and connected to a Safe Area PLC/DCS or other devices, via 2 wire communication link and the Gateway Unit D2050M, saving wiring, cables and costs.

The Units are primarily intended for Hazardous Areas acquisition of low level signal from Thermocouples, RTDs, mV or mA sources.

The Expander Units D2011M are controlled by D2010M



D2050M Gateway Unit.

Units. D2010M scans all enabled channels using state of the art solid state isolated relays, and stores all data in a memory buffer, where they can be rapidly accessed by the Modbus Gateway Unit D2050M.

Each Mux Unit accepts directly up to 16 input channels and, by adding from one to three Expander Units

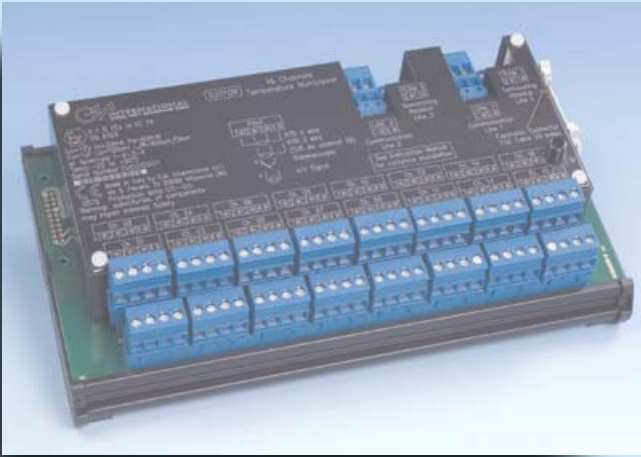

D2010M Multiplexer Unit.

D2011M, is expandable to 64 channels in blocks of 16 each. Four D2010M Units, connected to twelve D2011M Expanders reach 256 inputs with a single Modbus Gateway Unit D2050M. Redundant communication is obtained by in built dual data/supply interface line. Safety Parameters maintain capability with Gas Group IIC (A, B) even in redundant mode.

An Integrating type, High Rejection, High Accuracy (18 bits) A/D Converter, automatically calibrates Zero and Span providing accurate and stable measurements. All parameters are software configurable by serial commands via the D2050M Unit.

The Multiplexer Units D2030M, can be installed in the field close to input sensors, for data acquisition from Hazardous Areas and connected to a Safe Area PLC/DCS or other devices, via 2 wire communication link and Gateway Unit D2050M, saving wiring, cables and costs.

These Units are primarily intended for Hazardous Area acquisition from contacts or proximity detectors. D2030M scans all enabled channels and stores all data in a memory buffer, where they can be rapidly accessed by the Modbus Gateway Unit D2050M.

Each Mux Units D2030M accepts directly up to 32 inputs channels and from one to four Units can be used in a System.

Four D2030M Units reach 128 inputs with a single Modbus Gateway Unit D2050M.

Redundant communication is obtained by in built dual data/supply interface line.

Safety Parameters maintain compatibility with Gas Group IIC (A, B) even in redundant mode.

The D2052M Unit is equipped with 32 relay output SPDT contacts. Connected to D2050M Unit it repeats the status of each D2030M digital input Multiplexer Unit.

The D2053M Unit is equipped with 32 Open Collector Transistor Outputs. Connected to D2050M Unit it repeats the status of each D2030M digital input Multiplexer Unit.

Distance between Gateway Unit D2050M and the field Units D2010M, D2011M, D2030M can be up to 1000 mt. for gas group IIC (A, B) and up to 5000 mt. for group IIB, II A (C, D, E, F, G).

GM CABF008 is an available cable for communication lines between the D2050M Gateway and field Units.

NOTE: This cable is included in the system certification and it may be substituted only by cables with same specifications, in order for the certification to maintain its validity.

**ANALOG - TEMPERATURE MULTIPLEXER D2000M SERIES
SYSTEM SUITABLE for INSTALLATION in ZONE 0, 1, 2
CONFIGURATION for 64 TEMPERATURE INPUTS**

HAZARDOUS AREA

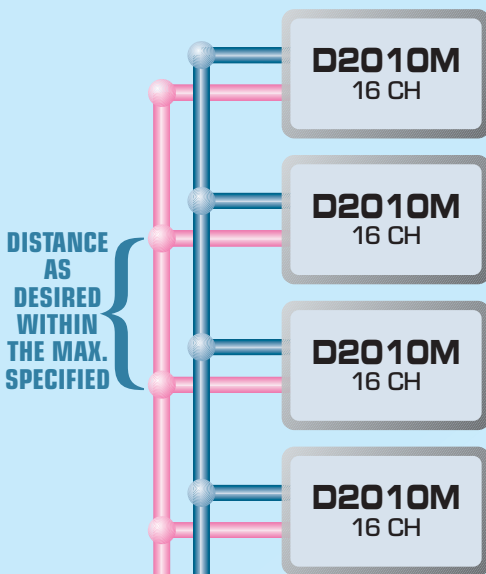

160 CHANNEL PER SECOND
MAXIMUM SCANNING TIME FOR
ALL CHANNELS: 400 mSec

MAXIMUM DISTANCE BETWEEN
D2050M and D2010M, using GM
Type CABF008 cable, is 1 Km
for GAS GROUP IIC and up to 5 Km
for IIB depending on configuration
(nr. of channels, nr. of units and their
distances).

SAFE AREA

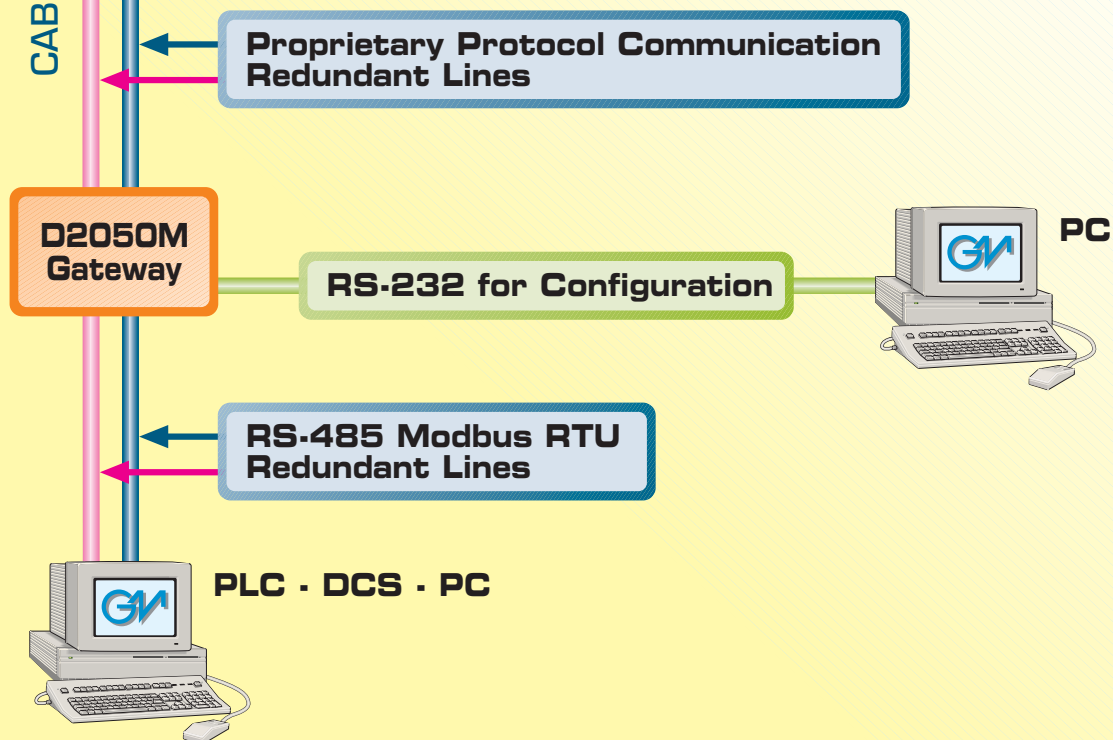

ANALOG - TEMPERATURE MULTIPLEXER D2000M SERIES SYSTEM SUITABLE for INSTALLATION in ZONE 0, 1, 2 CONFIGURATION for 256 TEMPERATURE INPUTS

HAZARDOUS AREA



CABLE DISTANCE: 150-300 mm

160 CHANNEL PER SECOND MAXIMUM SCANNING TIME FOR ALL CHANNELS: 1,6 msec.
 MAXIMUM DISTANCE BETWEEN D2050M and D2010M, using GM Type CABFO08 cable, is 1 Km for GAS GROUP IIC and up to 5 Km for IIB depending on configuration (nr. of channels, nr. of units and their distances).

SAFE AREA

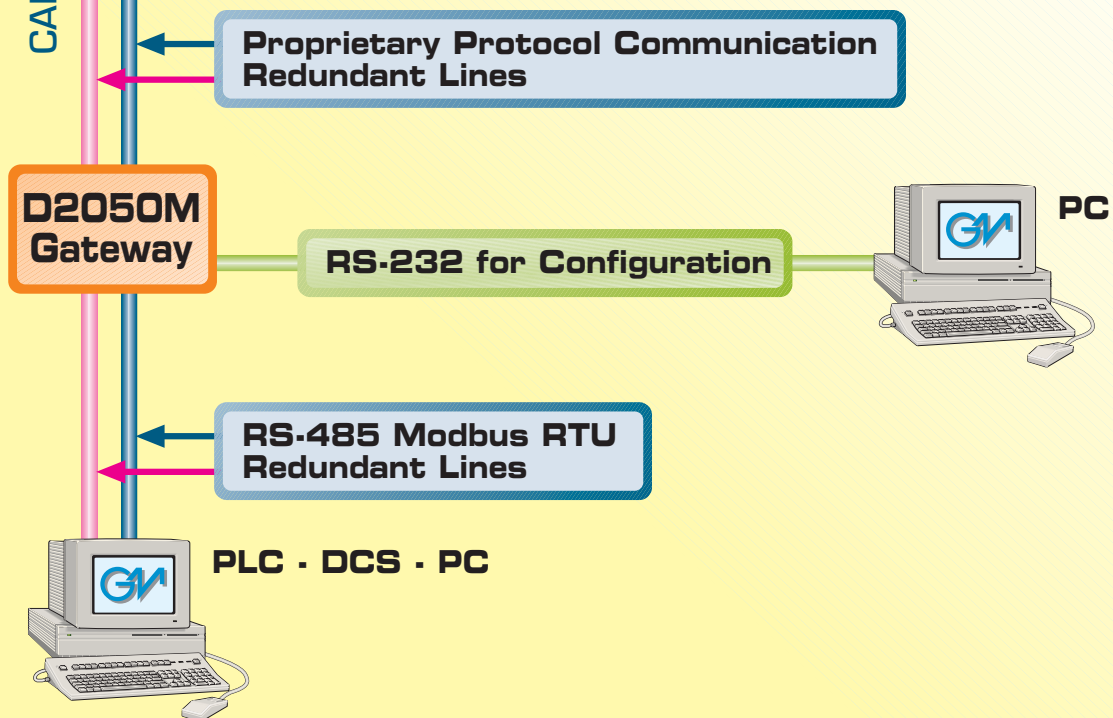

ANALOG - TEMPERATURE - DIGITAL MULTIPLEXER D2000M SERIES
SYSTEM SUITABLE for INSTALLATION in ZONE 0, 1, 2
CONFIGURATION for 192 TEMPERATURE and 32 DIGITAL INPUTS

HAZARDOUS AREA

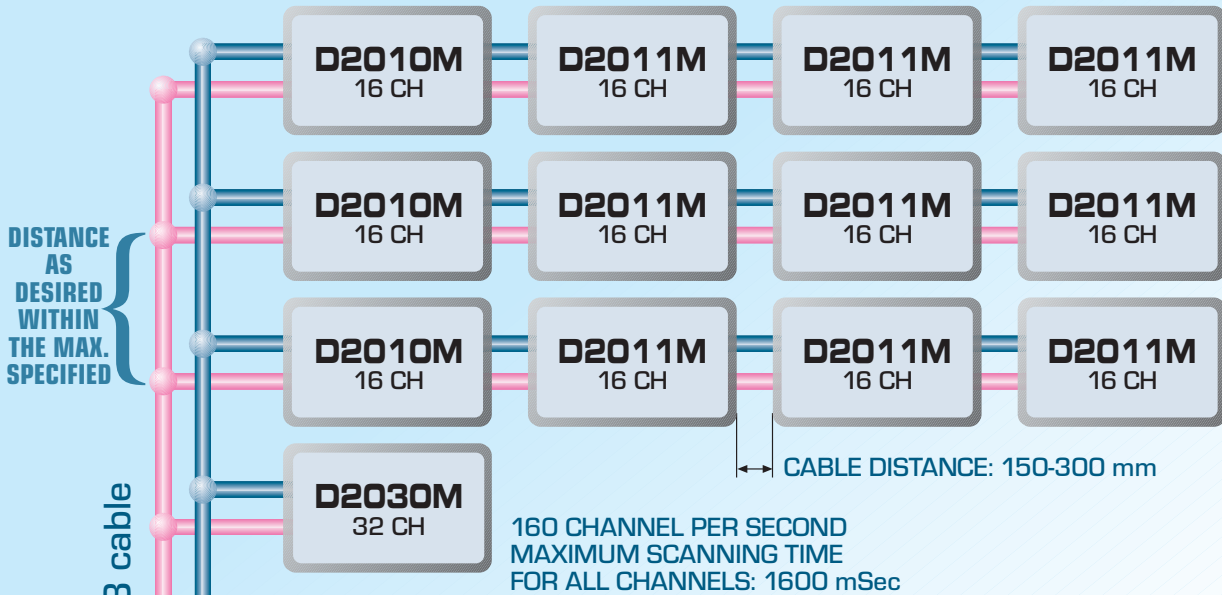

MAXIMUM DISTANCE BETWEEN D2050M and D2010M, using GM Type CABFO08 cable, is 1 Km for GAS GROUP IIC and up to 5 Km for IIB depending on configuration (nr. of channels, nr. of units and their distances).

SAFE AREA

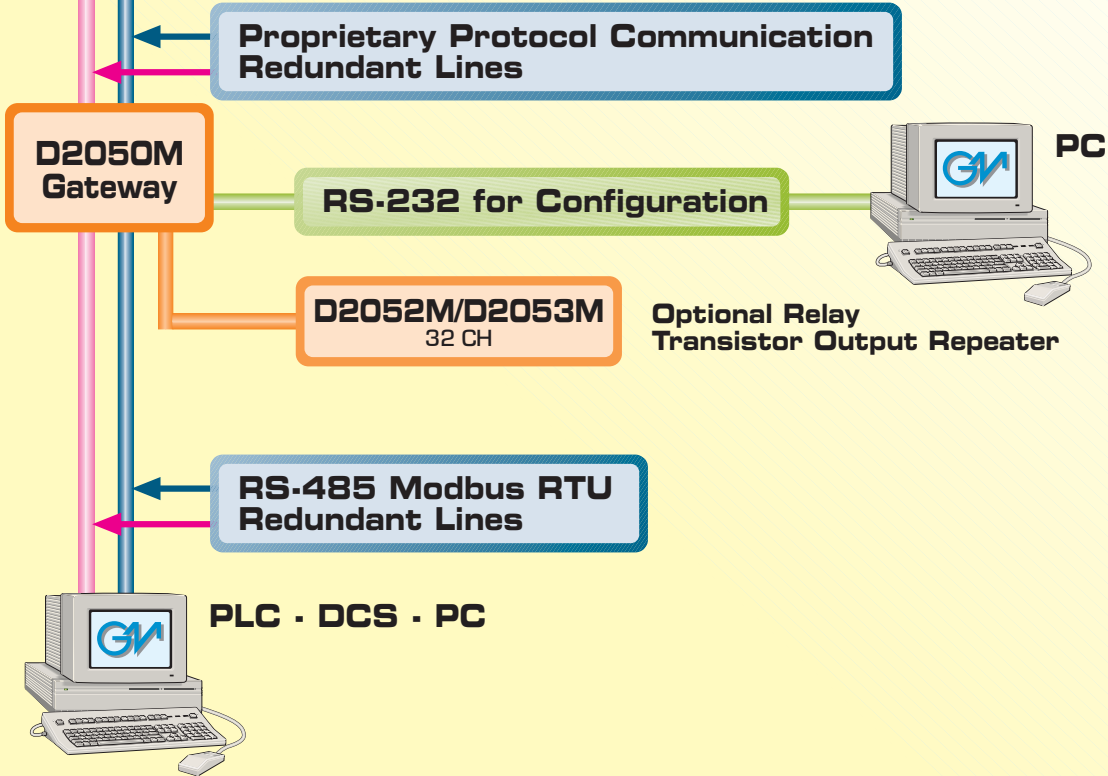

MULTIPLEXER D2000M SERIES SYSTEM SUITABLE for INSTALLATION in ZONE 0, 1, 2 MAX. CONFIGURATION for 128 DIGITAL INPUTS and 128 REPEATER OUTPUTS

HAZARDOUS AREA

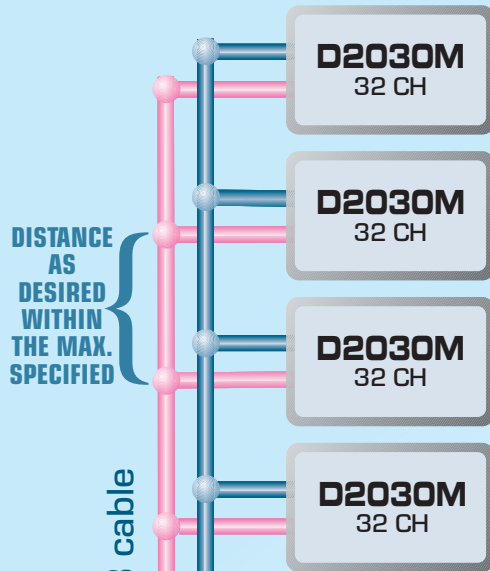

MAXIMUM SCANNING TIME FOR ALL CHANNELS: 50 mSec

MAXIMUM DISTANCE BETWEEN D2050M and D2010M, using GM Type CABF008 cable, is 1 Km for GAS GROUP IIC and up to 5 Km for IIB depending on configuration (nr. of channels, nr. of units and their distances).

SAFE AREA

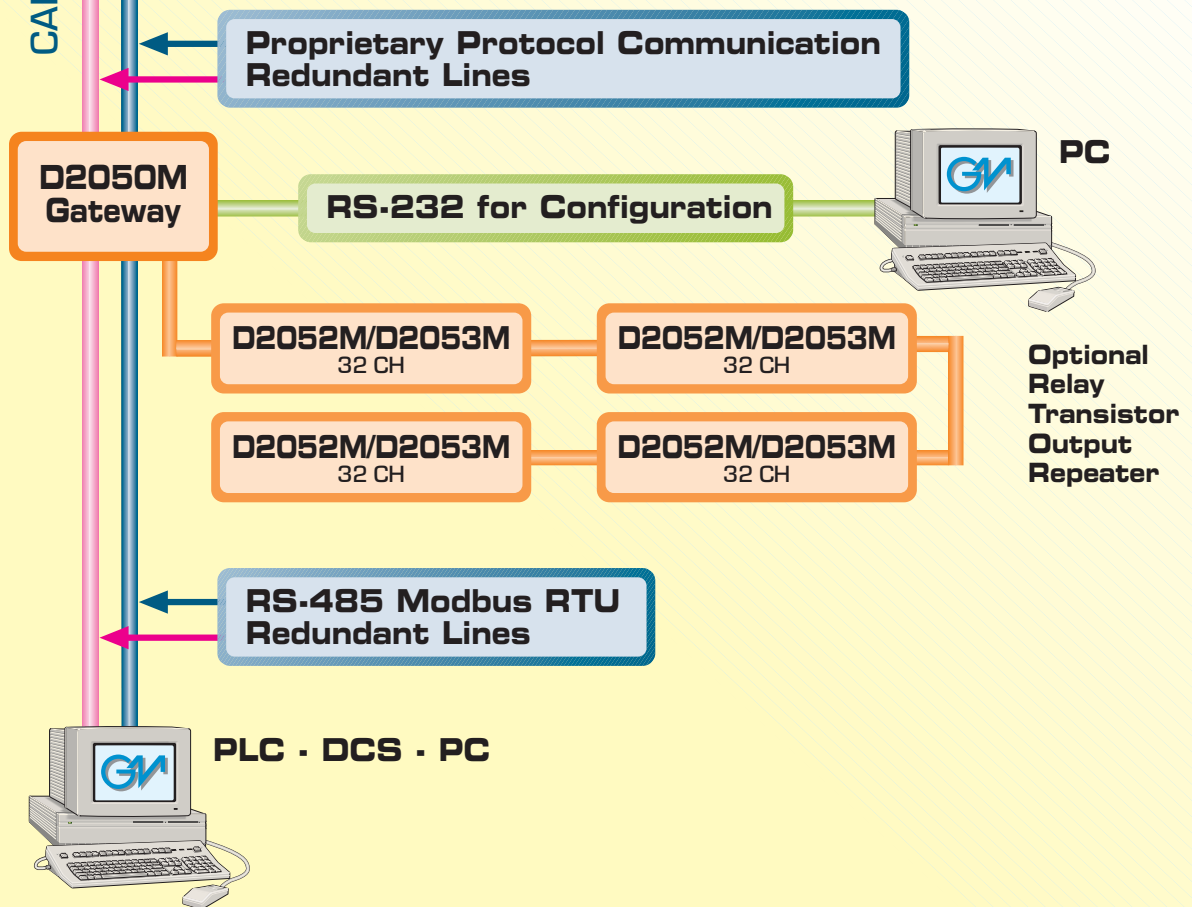

ANALOG - TEMPERATURE - DIGITAL MULTIPLEXER D2000 SERIES
SYSTEM SUITABLE for INSTALLATION in ZONE 0, 1, 2
CONFIGURATION for 128 TEMPERATURE INPUTS and 64 DIGITAL INPUTS

HAZARDOUS AREA

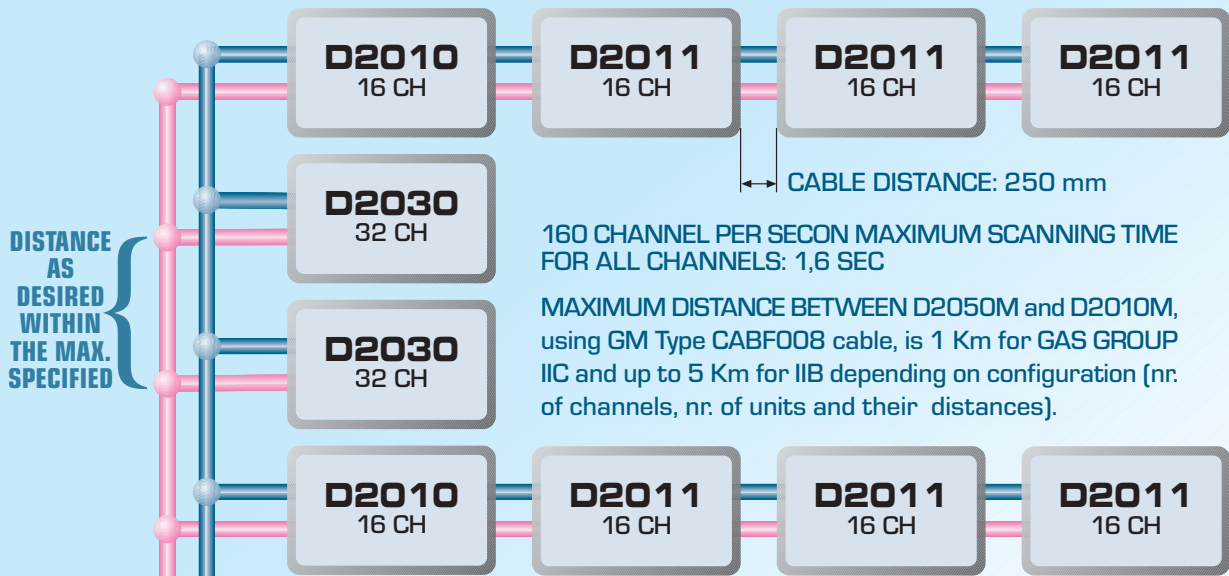

SAFE AREA

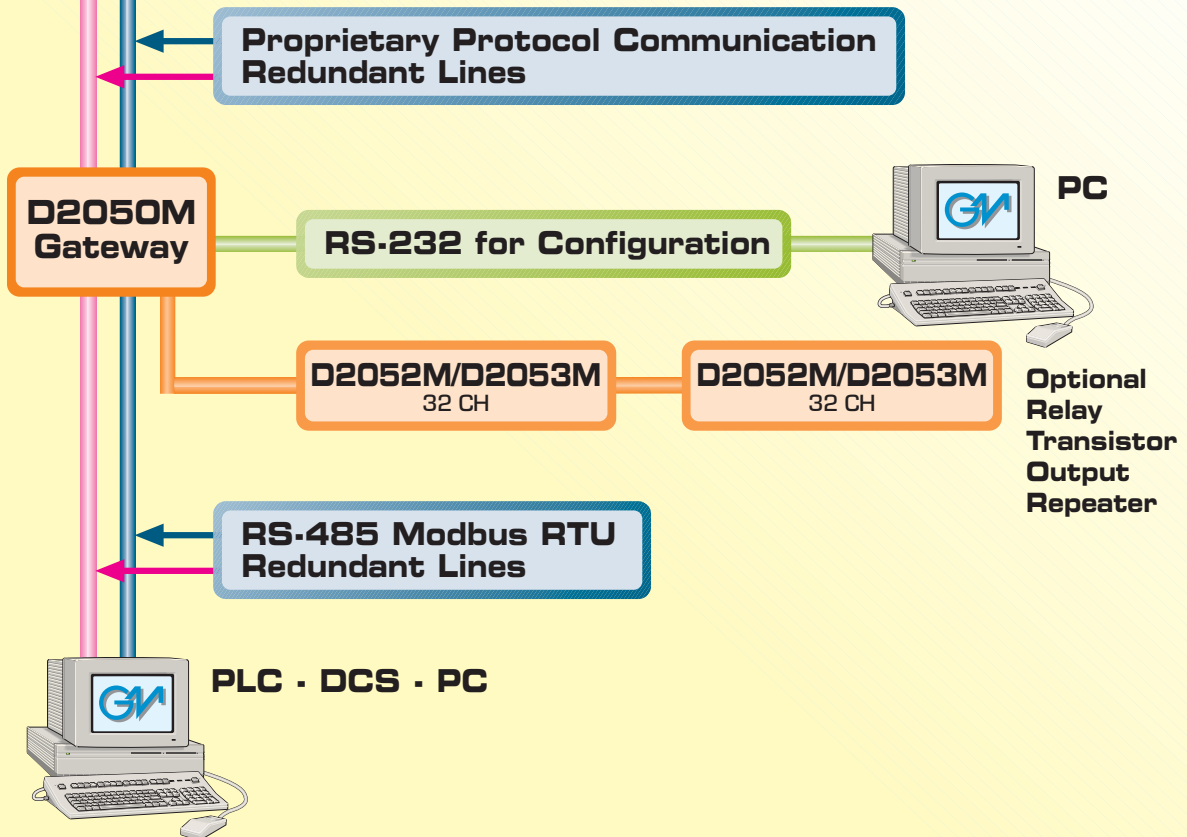

Configuring **D2010M,**
D2011M, D2030M
Field Units Using
a PC Serial Line via
the **Gateway D2050M.**
Configuration Software
Available, free of charge,
from G.M. web site.

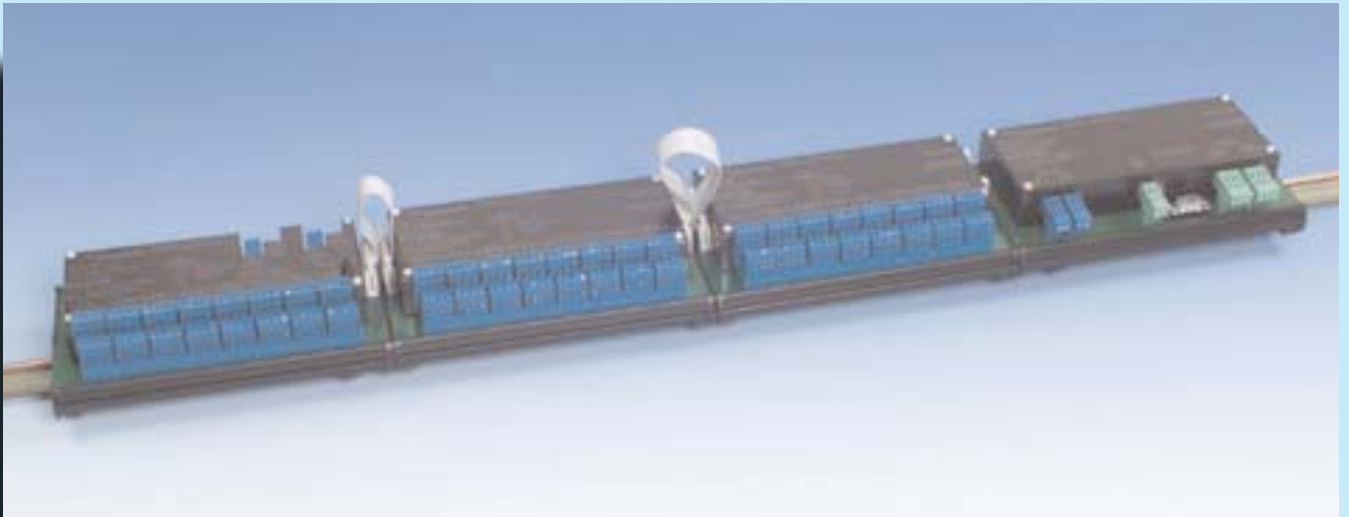

SWC 2090 MENU' OPTIONS

The SWC 2090 is the software to configure the D2000M Series Multiplexer System.

It is available from our website free of charge together with the "quick start guide".

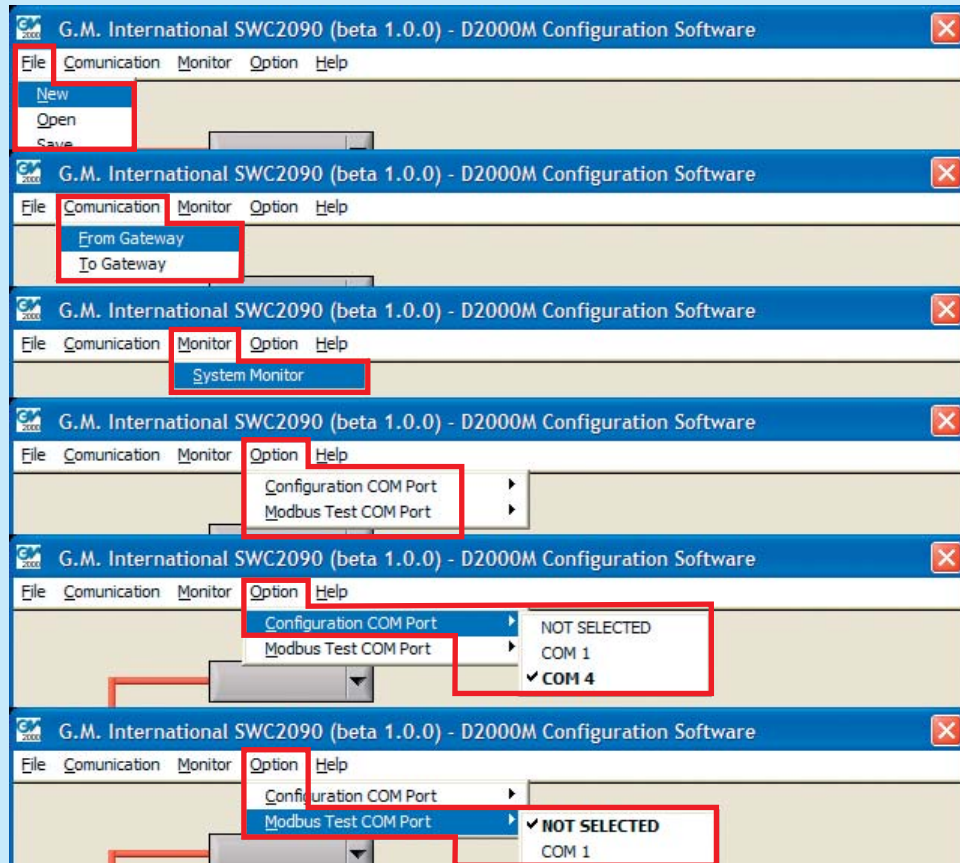

MULTIPLEXER MODUELS PROGRAMMING

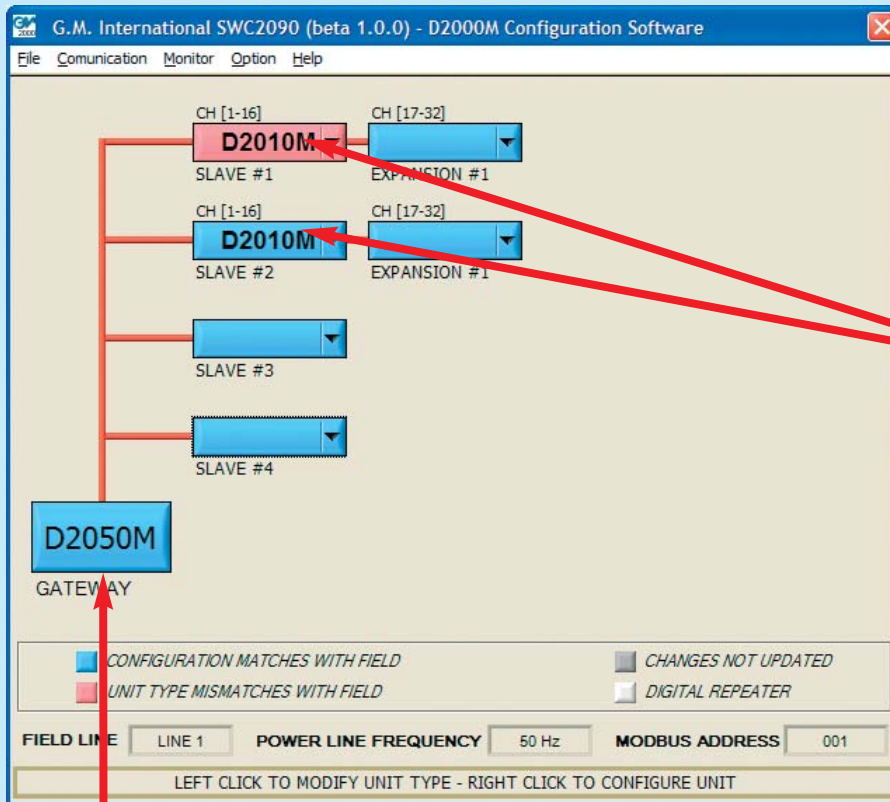

**LEFT CLICK
TO CHANGE TYPE
RIGHT CLICK
TO CONFIGURE UNIT**

**RIGHT CLICK
TO CONFIGURE
GATEWAY**

D2050M GATEWAY CONFIGURATION

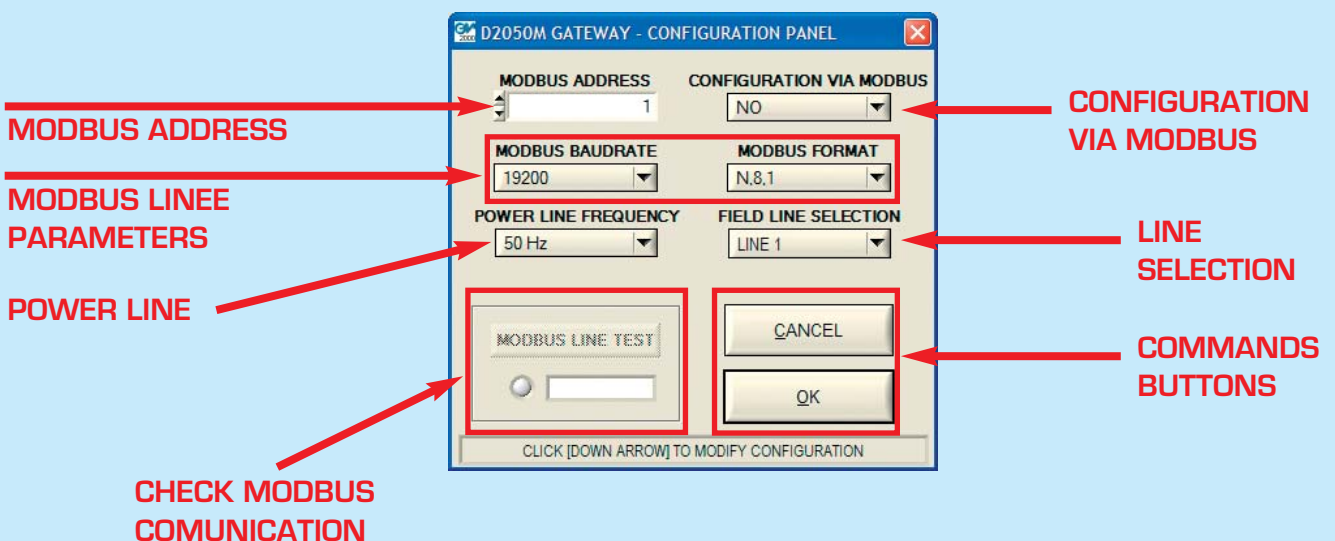

MODBUS ADDRESS

**MODBUS LINEE
PARAMETERS**

POWER LINE

**CHECK MODBUS
COMMUNICATION**

**CONFIGURATION
VIA MODBUS**

**LINE
SELECTION**

**COMMANDS
BUTTONS**

D2030M DIGITAL INPUTS UNIT PROGRAMMING

UNIT INFORMATION

CHANNEL OPERATING MODE SELECTION

EDIT TAG →

CHANNEL SCANTIME SELECTION

#	CHANNEL TAG	OPERATING MODE	SCANTIME	#	CHANNEL TAG	OPERATING MODE	SCANTIME
01	TAG CHANNEL 1	Ch. ON Fault ON	1 ms	17		Ch. ON Fault ON	1 ms
02		Ch. OFF	ms	18		Ch. ON Fault ON	1 ms
03		Ch. ON Fault OFF	ms	19		Ch. ON Fault ON	1 ms
04		Ch. ON Fault ON	1 ms	20		Ch. ON Fault ON	1 ms
05		Ch. ON Fault ON	1 ms	21		Ch. ON Fault ON	1 ms
06		Ch. ON Fault ON	1 ms	22		Ch. ON Fault ON	1 ms
07		Ch. ON Fault ON	1 ms			Ch. ON Fault ON	1 ms
08		Ch. ON Fault ON	3 ms			Ch. ON Fault ON	1 ms
09		Ch. ON Fault ON	5 ms			Ch. ON Fault ON	1 ms
10		Ch. ON Fault ON	8 ms			Ch. ON Fault ON	1 ms
11		Ch. ON Fault ON	10 ms			Ch. ON Fault ON	1 ms
12		Ch. ON Fault ON	12 ms			Ch. ON Fault ON	1 ms
13		Ch. ON Fault ON	14 ms			Ch. ON Fault ON	1 ms
14		Ch. ON Fault ON	16 ms			Ch. ON Fault ON	1 ms
15		Ch. ON Fault ON	18 ms			Ch. ON Fault ON	1 ms
16		Ch. ON Fault ON	20 ms			Ch. ON Fault ON	1 ms
		Ch. ON Fault ON	25 ms			Ch. ON Fault ON	1 ms
		Ch. ON Fault ON	30 ms			Ch. ON Fault ON	1 ms
		Ch. ON Fault ON	35 ms			Ch. ON Fault ON	1 ms

SINGLE CHANNEL SELECTION & MONITOR

01 Channel START ACQ OK CANCEL

CLICK [DOWN ARROW] TO SELECT CONFIGURATION OPTION

COMMAND BUTTONS AREA

D2010M & D2011M ANALOG TEMPERATURE UNIT PROGRAMMING

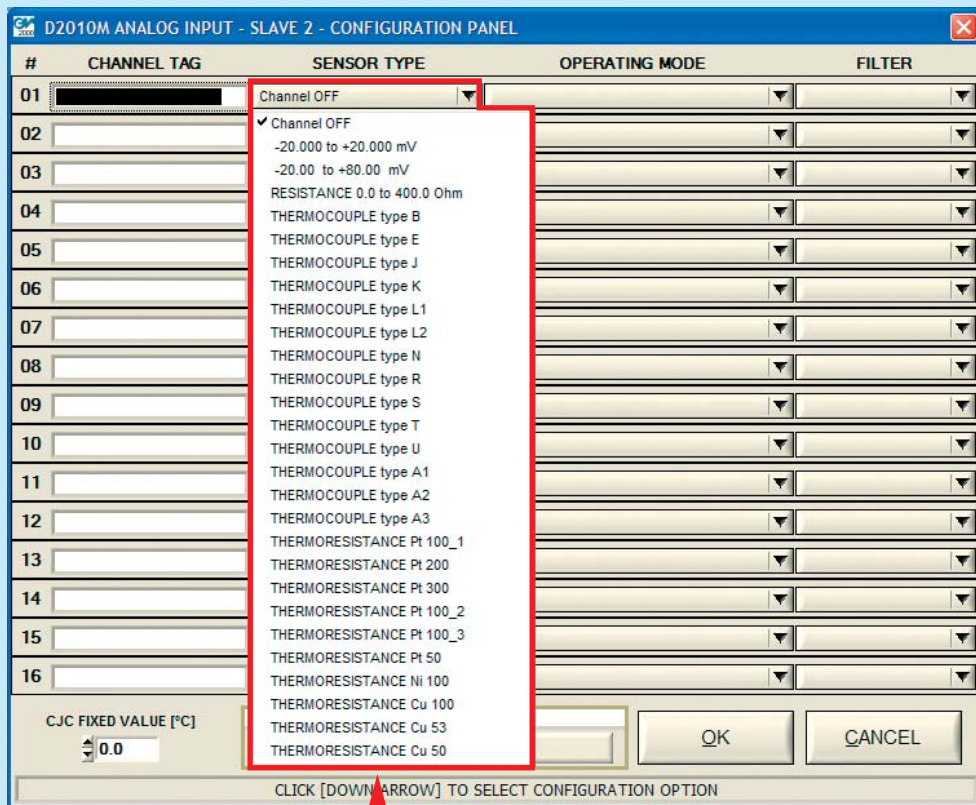

SENSOR TYPE SELECTION

D2010M & D2011M ANALOG TEMPERATURE UNIT PROGRAMMING

UNIT INFORMATION

OPERATING MODE SELECTION

AVERAGE FILTER SELECTION

D2010M ANALOG INPUT - SLAVE 1 - Configuration Panel

#	CHANNEL TAG	SENSOR TYPE	OPERATING MODE	FILTER
01		THERMOCOUPLE type B	AUTOMATIC CJC NO BURNOUT	SINGLE MEASURE
02		mV range #1	AUTOMATIC CJC NO BURNOUT	SINGLE MEASURE
03		mV range #1	AUTOMATIC CJC BURNOUT UP SCALE	SINGLE MEASURE
04		mV range #1	AUTOMATIC CJC BURNOUT DOWN SCALE	SINGLE MEASURE
05		mV range #1	FIXED CJC NO BURNOUT	SINGLE MEASURE
06		mV range #1	FIXED CJC BURNOUT UP SCALE	SINGLE MEASURE
07		mV range #1	FIXED CJC BURNOUT DOWN SCALE	SINGLE MEASURE
08		mV range #1	NO BURNOUT	SINGLE MEASURE
09		mV range #1	NO BURNOUT	SINGLE MEASURE
10		mV range #1	NO BURNOUT	SINGLE MEASURE
11		mV range #1	NO BURNOUT	SINGLE MEASURE
12		mV range #1	NO BURNOUT	SINGLE MEASURE
13		mV range #1	NO BURNOUT	SINGLE MEASURE
14		mV range #1	NO BURNOUT	SINGLE MEASURE
15		mV range #1	NO BURNOUT	SINGLE MEASURE
16		mV range #1	NO BURNOUT	SINGLE MEASURE

CJC FIXED VALUE [°C] 0.0

SINGLE CHANNEL MONITOR 01 Channel START ACQ

OK CANCEL

CLICK [DOWN ARROW] TO SELECT CONFIGURATION OPTION

VALUE FOR FIXED COLD JUNCTION COMPENSATION

SINGLE CHANNEL SELECTION & MONITOR

COMMAND BUTTONS AREA