

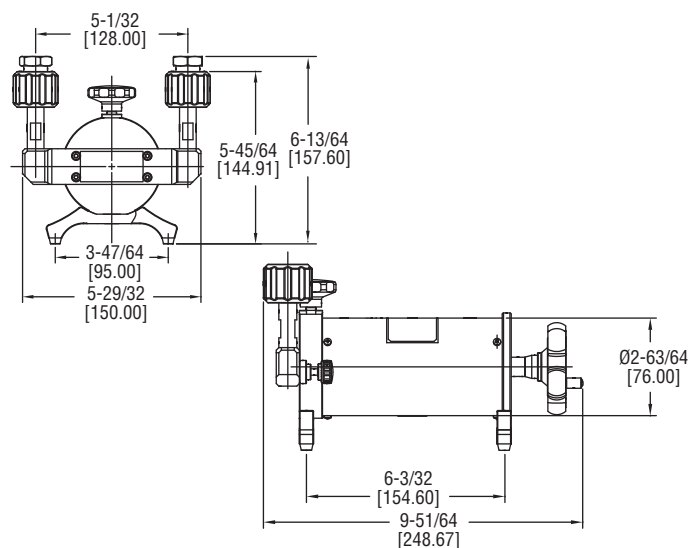

Model LPCP Low Pressure Calibration Pump

Specifications - Installation and Operating Instructions

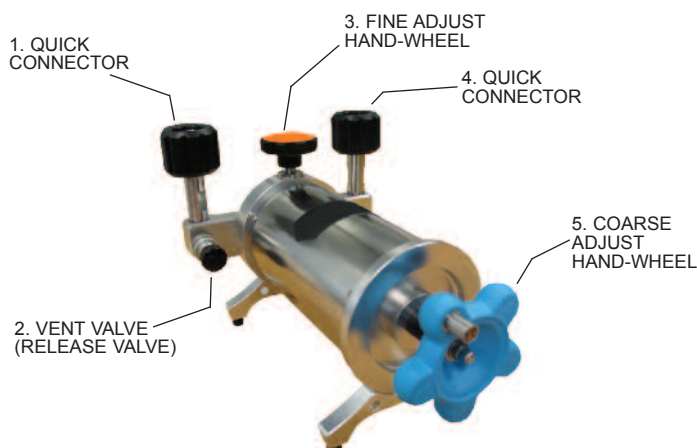

The Model LPCP Low Pressure Calibration Pump is a low air pressure source with the ability to easily adjust and stabilize. This hand pump possesses a pressure range of ± 5.8 psi; uses air as the media, and can adjust the pressure easily with great stability. The LPCP is made up of quick connectors for fast instrument connect and disconnect. The pump has a heat-insulator between the cover and pressure chamber to lessen the heat effect during the micro-pressure calibration. The adjusting resolution is up to 0.01 Pa (0.0001 mbar). These features make the LPCP ideal for calibrating pressure transducers, precision pressure gages, and other pressure instruments.

CONNECTION

Direct connection

If the connector of the unit under test is M20*1.5, please connect it with the hand pump directly.

Connect by pipe

If the connector of the unit under test is not M20*1.5, please use the other adapter to connect.

CALIBRATION PROCEDURE

Positive pressure calibration

1. First, make sure the vent valve (2) is open. Turn the coarse adjust hand-wheel (5) counterclockwise to the maximum and connect the reference gage and the gage under test on the ports (1) and (4) tightly.
2. Close the vent valve (2).
3. Turn the coarse adjust hand-wheel (5) clockwise to apply the pressure. Then use the fine adjust hand-wheel (3) to get the desired value.
4. Calibrate the next point until all calibration points are verified.
5. The next procedure is reverse calibration: turn the coarse adjust hand-wheel counterclockwise (5) to decrease the pressure. Turn the fine adjust hand-wheel (3) to get the desired pressure value. Calibrate the pressure one by one until all selected points are verified.

Negative (Vacuum) pressure calibration

1. First, make sure the vent valve (2) is open. Turn the coarse adjust hand-wheel (5) clockwise to the maximum. Connect the reference gage and the gage under test on the ports (1) and (4) tightly.
2. Turn the hand-wheel (5) counterclockwise to exhaust.
3. Close the vent valve (2). When the pressure approaches the desired vacuum value, stop. To fine adjust the pressure, use the hand-wheel (3). Calibrate all selected points one by one.
4. The operation procedure of reverse calibration, use coarse adjust hand-wheel (5) first, then use the fine adjust hand-wheel (3) to get the desired vacuum pressure.

SPECIFICATIONS

Media: Air.

Generated Pressure Range: 5.8 psi (0.4 bar) vacuum to 5.8 psi (0.4 bar) positive pressure.

Pressure Resolution: 0.01 Pa; 0.0001 mbar.

Material:

Ram/adapters: 316 SS;

Body: Steel/aluminum;

Seals: Buna-N.

Test Gage Connection: M20*1.5; 1/4" NPT with included adapters.

Reference Gage Connection: M20*1.5; 1/4" NPT with included adapters.

Dimensions:

Height: 5.7" (145 mm);

Base: 6.09" (155 mm) x 3.73" (95 mm).

Weight: 2.21 lb (1.0 kg).

NOTICE

PRECAUTIONS

1. Please don't add any oil or water into the pipeline.
2. To avoid damaging the airproof surface, please don't operate the shut-off valve aggressively.
3. This product can not directly calibrate pressure meters that are used under acid or alkali conditions. If necessary, you must make sure the meters are cleaned by CCl₄ solvent or melted oil spray to avoid any corrosion damage to the test pump.

MAINTENANCE

Upon final installation of the Model LPCP Low Pressure Calibration Pump, no routine maintenance is required. A periodic check of system calibration is recommended. The Model LPCP is not field serviceable and should be returned if repair is needed (field repair should not be attempted and may void warranty). Be sure to include a brief description of the problem plus any relevant application notes. Contact customer service to receive a return goods authorization number before shipping.

TROUBLESHOOTING

Problems	Causes	Solutions
Hard to Pressurize	A. Isolating/vent is not open.	Open the isolating/vent valve.
	B. Release valve is not closed.	Close the release valve.
	C. The gage under the test is loose.	Turn the reference gage and the gage under test tightly.
	D. O-seal has broken off.	Install or replace new O-seal (3 pieces, D= ø8).
	E. Flexible hose is loose.	Connect flexible hose well.
	F. Lever falls off.	Turn the lever clockwise.
	G. If the (±) conversion handle & port is correct or not.	Please confirm the position of conversion handle when system has no pressure.
Leakage Problems	A. For pressure gage under test, the screw's bottom surface isn't smoothed. (straight screw).	Use a transition joint with a PTFE seal in the joint which will be screwed tightly to the tested meter joint by a tool, then screw them tightly to the test pump again.
	B. The screw thread of test meter is taper screw.	Must use the PTFE plat seal and transition joint to tighten the screw thread, then screw them tightly with the pneumatic test pump again.
	C. Rubber seal on joint is aged or frayed.	Change O-seal (3 pieces, D= ø8).
	D. The system has been blocked, the cover of isolating and release valve is dirty.	Pressurize and release pressure again and again to drift impurity that is rested on seal surface of isolating or release valve.
	E. Test meter has leaks.	Replace other meter and test leakage again.
	F. Pressure pump leaks.	Connect the reference gage and block the other port with plugs tightly. Pressurize and check the airproof performance.
	G. Flexible hose leaks.	Cut 15 mm hose head and try again.
Other Attentions	A. Oil slide in system.	In order to avoid liquid impurity from test meter, suction back into test pump and confirm the location of (±) conversion handle before test.
	B. The movement components sound abnormal.	Lubricate the key components timing.
	C. The conversion seal loop of the (±) pressure is broken.	Should be switched under the system if no pressure.
	D. Some parts are aging.	Lubricate rubber seal periodically.